

KEYWAYS

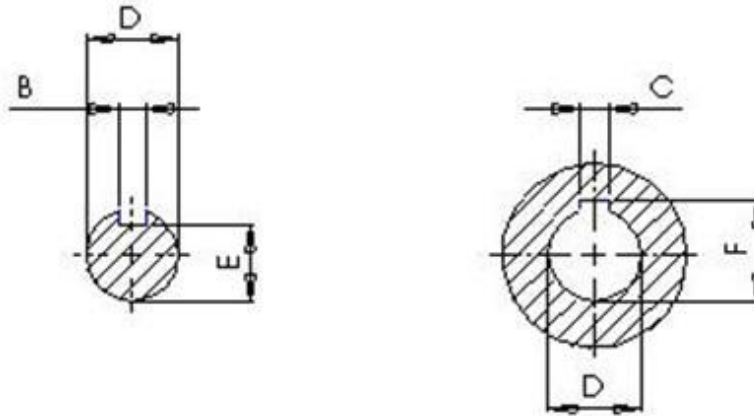

| KEY SIZE NOMINAL WIDTH x THICKNESS | SHAFT & BORE DIA. D | KEYWAY IN SHAFT | | KEYWAY IN HUB | | MAXIMUM BROACHING LENGTH |
|---|------------------------------|------------------------|----------------|------------------------|----------------|--------------------------------|
| | | B (P9 TOL.) | E | C (P9 TOL.) | F | |
| 2 x 2 | 8 | 2 -0.006 -0.031 | 6.8 +0 / -0.1 | 2 -0.006 -0.031 | 9.0 +0.1 / -0 | 32 |
| 3 x 3 | 9 | 3 -0.006 -0.031 | 7.2 +0 / -0.1 | 3 -0.006 -0.031 | 10.4 +0.1 / -0 | 30 |
| | 10 | | 8.2 +0 / -0.1 | | 11.4 +0.1 / -0 | 38 |
| 4 x 4 | 12 | 4 -0.012 -0.042 | 9.5 +0 / -0.1 | 4 -0.012 -0.042 | 13.8 +0.1 / -0 | 38 |
| 5 x 5 | 14 | 5 -0.012 -0.042 | 11.0 +0 / -0.1 | 5 -0.012 -0.042 | 16.3 +0.1 / -0 | 38 |
| | 16 | | 13.0 +0 / -0.1 | | 18.3 +0.1 / -0 | |
| 6 x 6 | 18 | 6 -0.012 -0.042 | 14.5 +0 / -0.1 | 6 -0.012 -0.042 | 20.8 +0.1 / -0 | 54 |
| | 19 | | 15.5 +0 / -0.1 | | 21.8 +0.1 / -0 | |
| | 20 | | 16.5 +0 / -0.1 | | 22.8 +0.1 / -0 | |
| | 22 | | 18.5 +0 / -0.1 | | 24.8 +0.1 / -0 | |
| 8 x 7 | 24 | 8 -0.015 -0.051 | 20.0 +0 / -0.2 | 8 -0.015 -0.051 | 27.3 +0.2 / -0 | 73 |
| | 25 | | 21.0 +0 / -0.2 | | 28.3 +0.2 / -0 | |
| | 28 | | 24.0 +0 / -0.2 | | 31.3 +0.2 / -0 | |
| | 30 | | 26.0 +0 / -0.2 | | 33.3 +0.2 / -0 | |
| 10 x 8 | 32 | 10 -0.015 -0.051 | 27.0 +0 / -0.2 | 10 -0.015 -0.051 | 35.3 +0.2 / -0 | 100 |
| | 35 | | 30.0 +0 / -0.2 | | 38.3 +0.2 / -0 | |
| | 38 | | 33.0 +0 / -0.2 | | 41.3 +0.2 / -0 | |
| 12 x 8 | 42 | 12 -0.018 -0.061 | 37.0 +0 / -0.2 | 12 -0.018 -0.061 | 45.3 +0.2 / -0 | 100 |
| 14 x 9 | 48 | 14 -0.018 -0.061 | 42.5 +0 / -0.2 | 14 -0.018 -0.061 | 51.8 +0.2 / -0 | 100 |
| 16 x 10 | 55 | 16 -0.018 -0.061 | 49.0 +0 / -0.2 | 16 -0.018 -0.061 | 59.3 +0.2 / -0 | -- |
| 18 x 11 | 60 | 18 -0.018 -0.061 | 53.0 +0 / -0.2 | 18 -0.018 -0.061 | 64.4 +0.2 / -0 | -- |

